



(11) (A) No. **1 231 872**

(45) ISSUED 880126

(52) CLASS 123-15

(51) INT. CL. F02M 21/04⁴

(19) (CA) **CANADIAN PATENT** (12)

(54) Hydrogen Injection System

(72) Meyer, Stanley A.,
U.S.A.

(21) APPLICATION No. 449,242

(22) FILED 840309

(30) PRIORITY DATE U.S.A. (478,207) 830323

No. OF CLAIMS 26

Canada

ABSTRACT

System and apparatus for the controlled intermixing of hydrogen/oxygen gasses with non-combustible gasses to reduce the burning temperature and velocity of the hydrogen gas in a burner. The system utilizes a hydrogen generator for developing the hydrogen/oxygen gasses. The hydrogen gas with non-combustible gasses are intermixed in a controlled air intake chamber. The exhaust gasses of the burner are returned as the non-combustible gasses to the mixing chamber in a closed loop arrangement. Upon attaining the proper burning temperature and velocity of the hydrogen gas the ratio of hydrogen/oxygen and non-combustible gasses is maintained. To effect a practical utilization, the generation of the hydrogen/oxygen gasses are controlled in start-up and in quantity. The control of the generation of gasses is effected by one or more variable parameters; such as varying the voltage applied to the plates, varying the pulse rate of the voltage on the plates, varying the spacing between the plates, switching the number of plates, and plate configuration. The hydrogen/oxygen generation is on demand; that is the hydrogen/oxygen generation on start-up is only on demand and thereafter generation is controlled in quantity by the need much in the same manner as an accelerator.

CROSS REFERENCE AND BACKGROUND

This application is related to my earlier filed Canadian patent Application Serial No. 420,889 filed February 4, 1983.

5 There is disclosed in my co-pending Canadian patent application, filed September 16, 1981, Serial No. 420,908 for a Hydrogen Generator, a generating system for converting natural water into hydrogen and oxygen gases. In that system, the hydrogen atoms are disassociated from
10 the water molecules by the application of a non-regulated, non-filtered, low power, direct current/voltage electrical potential applied to two non-oxidizing similar metal plates having natural non-electrolytic water passing therebetween. The action is enhanced by pulsing the non-regulated and
15 non-filtered direct current/voltage. Particularly significant with the hydrogen generator disclosed in such application Serial No. 420,908, is that the hydrogen/oxygen generated is in excess of that necessary for practical utilization. Further, and equally significant, is that the generation
20 of the hydrogen/oxygen is controlled by any one or more of several factors, i.e. varying voltage, varying pulse rate, varying spacing between plates, switching the number of plates, and plate configuration.

 Therefore, the hydrogen/oxygen generation
25 of my co-pending patent application, supra and utilized in the preferred embodiment herein, is a demand system; that is, generation of the hydrogen/oxygen is initiated upon demand. Then, the generation of the hydrogen/oxygen



is controlled in quantity by the need; such as, accelerator for an automotive device.

Another earlier system utilizes a rotational mechanical gas displacement system to transfer, meter, mix, and pressurize the various gases. In the gas transformation process, ambient air is passed through an open flame gas-burner system to eliminate gases and other substances present. Thereafter, the non-combustible gas-mixture is cooled, filtered for impurity removal, and mechanically mixed with a pre-determined amount of hydrogen gas. The gas formation stage also meters the volume and determines the proper gas-mixing ratio for establishing the desired burn-rate of hydrogen gas. The rotational mechanical gas displacement system determines the volume-amount of gas to be produced. This is a multi-stage system having utility in special applications. The hydrogen generator system of the above-mentioned co-pending patent application discloses a very simple and unique hydrogen generator.

SUMMARY OF INVENTION:

The system of the present invention, in its most preferred embodiment, is for a combustion system having utility in a mechanical drive system, and particularly, in one instance, to drive a piston in an automotive device. The system utilizes the generator of my above-mentioned co-pending Application 420,908 for developing hydrogen gas, and other non-combustible gases such as oxygen and nitrogen. The hydrogen gas with the attendant non-combustible gases, in a controlled ratio, are fed via a line to a

controlled air intake system. The combined hydrogen, non-combustible gases and the air, after intermixing, are fed to a combustion chamber wherein the mixture is ignited. The exhaust gases of the combustion chamber are returned
5 in a closed loop arrangement to the mixing chamber.

More specifically the generated hydrogen gas is fed to a gas mixing chamber wherein the hydrogen gas is intermixed with non-combustible gases. The mixture is fed to a carburetor (air intake mixture) system.

10 The gas mixture is fed through nozzle means into a chamber in a jet spray. Valve or gate means controls the amount of air intake to the jet spray. The gases combine with the air to form a gas mixture of hydrogen, non-combustible gas, and oxygen. The mixture, now combustible but not
15 as highly combustible as hydrogen by itself, is entered into a combustion chamber. The chamber may be conventional in design comprising a cylinder capable of withstanding high pressure and having a piston reciprocable therein. At the uppermost end of the combustion chamber there is
20 a spark plug igniter.

The exhaust gases, the residue of the combustion, now comprise a non-combustible mixture. These exhaust gases are fed to the gas mixing chamber as the non-combustible gases in a closed loop arrangement.

25 To effect a practical utilization, the generation of the hydrogen/oxygen gases are controlled in start-up and in quantity. The control of the generation of gases is effected by one or more variable parameters; such as

varying the voltage applied to the plates, varying the pulse rate of the voltage on the plates, varying the spacing between the plates, switching the number of plates, and plate configuration. The hydrogen/oxygen generation is on demand; that is, the hydrogen/oxygen generation on start-up is only on demand and thereafter generation of the gases is controlled in quantity by the need, much in the same manner as an accelerator.

A principal object of the present invention is to provide a combustion system of gases combined from a source of combustible and non-combustible gases.

A further object of the invention is to provide a hydrogen generator that is controllable in the generation of hydrogen/oxygen gases and therefore capable of controlling the rate of firing of a burner system.

A further object of the invention is to provide a hydrogen generator and combustion system that may be incorporated in a mechanical drive system.

In keeping with the foregoing, there is provided in accordance with the present invention a burner system comprising: a hydrogen/oxygen generator; a housing having a water reservoir for retaining water therein having no electrolyte added thereto; a pair of similar electrical voltage conductive non-oxidizing, non-corrosive, non-reactive plates positioned in said water reservoir in spaced apart relation with respect to one another; a direct current voltage source having positive and negative output terminal connected to respective ones of said pair of plates to

apply a low current electrical voltage for disassociating
the hydrogen gas atoms and oxygen gas atoms from the water
molecules; and a gas mixing chamber; conduit means including
first control valve connecting the hydrogen/oxygen combustible
5 gases from said hydrogen/oxygen generator to said mixing
chamber; a source of non-combustible gas; conduit means
including a second control valve connecting the non-combustible
gas from said non-combustible source to said mixing chamber;
said combustible gas and non-combustible respective first
10 and second gas control valves regulating the gas mixture
ratio of combustible/non-combustible gases from said mixing
means; air-intake means connected to the output of said
mixing chamber for combining air with said mixed gases;
a gas burner having said controlled amount of mixed gases
15 from said mixing chamber and air mixed therewith fed thereto;
means to ignite said gas/air mixture in said gas burner;
and demand control means for varying the release of said
hydrogen/oxygen gas atoms to thereby accelerate and decelerate
the rate of ignition of said gas/air mixture.

20

BRIEF DESCRIPTION OF THE DRAWINGS

The invention is illustrated by way of example
in the accompanying drawings wherein:

Figure 1 is a schematic cross-sectional illustration
25 of one embodiment of the present invention;

Figure 2 is a block schematic illustration of the preferred
embodiment of Figure 1;

Figure 3 is an alternative gas system replacement for
that shown in Figure 1;

Figure 4 is a block schematic illustration of a complete drive system utilizing the concepts of the present invention;

5 Figure 5 is a basic schematic drawing of the hydrogen generator utilized in the preferred embodiment as the motive force in a drive system;

Figure 6 is a further application of the present invention in a regenerative energy feedback system;

10 Figure 7 illustrates the voltage potential as applied to several plates;

Figure 8 is a graph illustration of the burning velocity of standard fuels for a land vehicle;

15 Figure 9 is a graphical illustration of gas generated versus different applied power, for various types of water conditions;

Figure 10 is a graph illustrating gas generated versus pulse direct current repetition rate;

20 Figure 11 is a graphical illustration of gas generation for three different geometrical configurations of plate structure; and

Figure 12 is a graphical illustration of gas generated with the plates having increasing separation.

DESCRIPTION OF PREFERRED EMBODIMENTS

25 Figure 1 illustrates a complete overall combustion system together with a piston and cylinder of an internal combustion engine. Similarly, Figure 2 illustrates the complete system in its preferred embodiment.

With particular reference to Figure 1, the hydrogen source 10 is the hydrogen generator disclosed and described in my co-pending application, supra. The container 102 is an enclosure for a natural water bath 2. Immersed in the water 2 is an array of plates 3 of similar non-oxidizing material. Applied to plates 3 is a source of pulsed direct current potential via electrical inlet 27.

The action of the pulsed direct current, a voltage/current potential, on the plates causes the hydrogen and oxygen atoms to become disassociated from the water molecule.

Varying either the potential of the direct current source or the pulse rate of the pulsing of the direct current potential will vary proportionately the generation of the hydrogen/oxygen. Other factors are disclosed for varying the output of the generator.

More specifically with reference to Figure 5, to be taken in conjunction with the generator 10, of Figure 1, there is illustrated schematically in cross-section the hydrogen/oxygen generator in its most simplified embodiment.

The container 102 holds supply of water 2 which is natural water and can be either pure distilled water, or salt, or tap, well, rain, river, or other water containing contaminants. However, specifically, no electrolyte or chemicals are added to the water. The water 2, comprising molecules $2a \times 2n$ of hydrogen $3a \times 3n$, oxygen $4a \times 4n$, and foreign substances $5a \times 5n$, is passed between a pair of plates 9a and 9b, consisting of similar non-oxidizing metal, submerged therein.

To replenish the expended water the generator is connected via line 1 to a suitable water source.

Attached to terminal 32 on plates 9a is a wire having its other end connected to the negative terminal, and to terminal 31 on the plate 9b is connected another wire having its other end connected to the positive terminal of the direct current electrical source 30A.

The direct current voltage applied to the water passing between plates 9a and 9b, is sufficient to disassociate the hydrogen atoms and oxygen atoms (appearing as bubbles) from the water molecules. The foreign substance or contaminants are broken away from the water molecule and spillover the outside areas of the plates 9a and 9b to a collector at the bottom of the container 102. The hydrogen gas and oxygen gas rises above the liquid.

As illustrated in Figure 9, increasing the voltage applied to the plates 9a and 9b enhances the action upon the water molecule, which in turn increases the hydrogen/oxygen gas generation. The gas generated is substantially a linear function to the magnitude of the voltage applied to the plates. Therefore, by increasing or decreasing the direct current voltage potential applied to the plates the hydrogen/oxygen rate of generation is directly related. Also, and most significantly, the voltage is increased and decreased but the current is maintained constant at a very low level. That is, the direct current voltage potential is current limited.

As shown in Figure 10, it has also been found that pulsing the voltage applied to the plates 9a and 9b enhances the action upon the water molecule, which in turn increases the hydrogen/oxygen gas generation.

5 The gas generated is a linear function to the pulse repetition rate of the voltage applied to the plates 9a and 9b.

A safety release valve 28 is used to avoid excessive gas buildup and the switch 29 is a gas pressure switch to maintain a predetermined gas pressure level.

10 The generated hydrogen gas 4 is fed via pipe 5 to a gas mixing chamber 40, wherein the hydrogen gas is inter-mixed with non-combustible gases such as, for example, exhaust gases 22 as more fully discussed hereinafter.

15 The mixture of combustible gas and non-combustible gases are fed via pipe line 9 to a carburator (air-mixture) system 20.

The gas mixture 8 is fed through nozzle 11 to chamber 47 in a jet spray 46. Valve or gate 45 controls the amount of air-intake which combines with the gas mixture of jet spray 46. The mixture of air, hydrogen and non-combustible gases enters combustion chamber 30, via pipe line 16. The chamber 30 may be conventional in design and comprises a cylinder 17 capable of withstanding high pressure. At the uppermost end of the combustion chamber 30 is a spark plug igniter 18.

25 In a controlled manner, relative to the piston 23 stroke, the spark ignition 19 via spark plug 18, causes the mixed gases to combust. The compression 21

caused by the combustion forces the piston 23 to push downwardly in the cylinder 17.

The exhaust gases 22, the residue of the combustion 21, now comprises a non-combustible mixture.

5 These exhaust gases 22 are fed via pipe line 24 to the gas mixing chamber 40 as the non-combustible gases as aforesaid.

The pipe line 24 passes through cooling chamber 50 for cooling of the gases therein. The cooling chamber 50 also functions as a spark arrestor to eliminate
10 the possibility of gas ignition inside the mixing chamber 40. The excess non-combustible gases are exhausted via outlet 49, to be expelled into the atmosphere.

The apparatus of Figure 2 comprises much the same system as Figure 1. In this embodiment the components
15 are depicted more explicitly in their structural relationship in an alternate arrangement. Basically, the system is operable as that in Figure 1, i.e. a mixture of combustible (hydrogen) gas and non-combustible gases (exhaust).

The hydrogen generator 10, as aforesaid,
20 may be any form of a generator, however, in the preferred embodiment the hydrogen generator is that of my co-pending application, supra. The water system in a closed loop operation comprises a reservoir or tank 39 with an outlet having pipe line 33 connected thereto, water control valve 54
25 being operable to adjust the water flow. The water is pumped by pump 34 in line 33 to line 35, and then to the generator 10.

The overflow water expended and non-expended is expelled from generator 10 into line 36, filtered in filter 41 of contaminants, and returned to tank 39 via pipe line 37. The loop is completed.

5 The gases generated from the water in generator 10 also includes the oxygen component of the water in addition to nitrogen.

10 The outlet 5 on the generator 10 receives the combustible and non-combustible (oxygen and nitrogen) gases generated thereby and feeds the same to the mixing chamber 40. The flow of the hydrogen gas is, of course; critical; therefore, there is incorporated in line 5 a gas flow valve 53 (Fig. 2) to adjust the hydrogen flow.

15 The exhaust gases 22 are fed via inlet pipe 31 to the cooling and spark arrestor chamber 50 and by pipe 24 into the mixing chamber 40. These gases from cooling and spark arrestor chamber 50 to mixing chamber 40 are controlled by a flow control valve 51 in pipe line 24.

20 The output of gases from mixing chamber 40 as described relative to Figure 1 and 2 is fed via line 9 to an air/gas mixture system 42. In this instance, the intake air 14 may be in a carburetor arrangement with an intake adjustment 55 that adjusts a plate on an air intake opening of the air/gas mixture system 42. The gas mixture is fed into the carburetor by nozzle 11 and mixed with
25 the air 14.

With particular reference to Figure 3 there is illustrated an alternative combustion chamber 60 that may be utilized in lieu of the chamber 30 of Figure 1.

In this embodiment the combustible and non-combustible gas mixture that is generated and mixed in the arrangement of Figures 1 and 2, enters inlet 8 and is directed by pipe line 9 and nozzle 11 to the cone 65.

5 The gas mixture combines with air 14 as it enters cone areas 65. The combined gas mixture is directed by the cone 65 to the dispersing chamber 66. There the gas mixture is further mixed with air 14 to form combustible gas. The gas/air mixture is dispersed via ports 67a xxx 67n
10 from the dispersing chamber 66 into the firing area of the combustion chamber 60.

The gas mixture entering inlet 8 is also fed by pipe line 9 to a separation chamber 71. This chamber sections off a controlled amount of the intake gas mixture
15 to the pilot light line 58. The pilot light firing 57 is sequenced by the drive, much in the same manner as the cylinder of an automobile engine.

The mixed gas designated 56a, 56n, ejected from ports 67a xxx 67n of the dispersing chamber 66 is
20 ignited by the pilot light combustion 57 in the firing area of the combustion chamber and thereby causing combustion 59 of the mainstream gases.

As the non-combustible gases (exhaust gases 22 of Figure 1) rise upwardly in the cylinder 61, of the combustion
25 chamber 60 the cone 63 captures a portion of such non-combustible gases. The captured exhaust gas is returned via pipe line 68 and outlet 74 to the combustion process as set in Figure 1 or expelled for other purposes.

The major portion of the non-combustible gases by-pass the cone 63 and rise further to the outlet exhaust 69 and are expelled at opening 73.

In the constructed arrangement of Figure 4, there is illustrated a gas control system that may be retrofitted to an existing automobile internal combustion engine without changing or modifying its design parameters or characteristics.

As low-voltage direct current is applied to safety valve 28, solenoid 86 is activated. This results in applying a control voltage to the hydrogen generator plates 3 via terminal 27 through pressure switch 29. Hydrogen gas produced in hydrogen generator 10 passes through flow adjustment valve 53 and then outlet pipe 5 for utilization.

Gas regulator valve 75 is utilized to reduce the pressure level inside hydrogen generator 10. The pressure differential hydrogen gas output to gas mixing chamber 40 is, for example, 30 lbs. to 15 lbs. Once hydrogen generator 10 reaches an optimum gas pressure level, pressure switch 29 shuts off electrical power to the hydrogen exciters. If the chamber pressure exceeds a predetermined level, the safety release valve 28 is activated disconnecting the electrical current and thereby shutting down the entire system for safety inspection.

Similar to an automobile engine or other drive force requiring an electrical energizing source, the present invention may include the regenerative energy feedback arrangement shown in Figure 6.

1231872

The process utilizes a mechanical drive system as described relative to Figures 1 and 2; and which mechanical drive may be that of a piston such as utilized in a gasoline engine. In operation, the process mixture is ignited much in the same manner as in Figure 1. The drive mechanism in turn activates electrical voltage of alternator 95 whose output is fed back to the hydrogen generator and utilized as the firing voltage on the spark plug 18; again, in a closed loop arrangement.

The ratio of hydrogen/oxygen gases is varied to obtain optimum burning velocity and temperature for the particular combustion engine. Once this is attained, the ratio, under normal conditions, will not be altered. Other engines having different fuel burn temperature and velocity will be adjusted in ratio of hydrogen/oxygen to non-combustible gases in the same manner as exemplified above.

With reference to Figure 8 there is illustrated the burning velocity of various standard fuels. It can be seen the common type of fuel for a land vehicle burns at a velocity substantially less than with hydrogen gas.

In an application of the preferred embodiment to the present invention i.e., an automobile, the proper burning velocity and temperature will be attained as aforesaid, to match that of the gasoline burning engine, the burning engine or its particular fuel. This ratio once attained will not be altered. In operation of the engine, when the engine is not running, there is no tank of hydrogen

fuel in the automobile, such as suggested by the prior art. Applicant's automobile simply has a tank of water. Upon start-up, hydrogen/oxygen from the tank of water is immediately generated, and ignition takes place. Again,
5 only enough hydrogen/oxygen is generated to effect combustion.

Further, in operation of the automobile utilizing the present invention, when it is desired to accelerate the firing rate of the engine, such as may occur in normal driving, the rate of generation of the hydrogen/oxygen
10 is accelerated by the demand controls. The greater demand for acceleration, the greater the generation of the gases.

Again, in the practical working embodiment of the automobile utilizing the hydrogen/oxygen engine of the present invention, the "throttle" for accelerating
15 the speed of the engine will be an electronic control. This may be such as for varying the pulse rate or the magnitude of the voltage of the direct current voltage potential applied to the plates of the generator.

In lieu of increasing the electrical power or varying the pulse rate to enhance the action on the
20 water molecules, other conditions have been considered.

With particular reference to Figure 7 there is illustrated an electronic switch for switching on and off the rippled d.c. output of supply 30a. The plates
25 32a xxx 32n are connected to common ground 34. The positive terminals 33a xxx 33n are connected respectively to contacts 31a xxx 31n of switch 35a rotatively making and breaking contact with the direct/current voltage source 30a.

It can be appreciated the greater the number of cells the more hydrogen/oxygen generated. In a practical embodiment, the combustion engine is started on a minimum number of cells. Upon acceleration, the greater the need
5 for more hydrogen/oxygen gas, hence the increase in the number of cells. In this way, the switch 35a is an accelerometer.

Again, in that the increase in generation of hydrogen/oxygen by the actuation of switch 35a, the increase is a step function. It is deemed desirable therefore,
10 that the configuration of switch control of cells be in conjunction with the aforesaid linear type of acceleration.

Other structure factors altering, affecting, and particularly enhancing the hydrogen gas generating comprises altering plate spacing, and the plate configuration.
15 Each of these factors have been taken into consideration in the development of a fuel cell to provide optimum results for a preferred embodiment.

As stated above, another factor affecting the gas generation output is the plate separation. With
20 particular reference to Figure 12 there is illustrated graphically plate spacing versus gas generation. As can be seen, the greater the spacing the less gas generation. The efficiency versus spacing of the plates is a linear decrease with spacing.

With particular reference to Figure 11,
25 there is illustrated graphically the efficiency of the tubular plate array, the cluster tubular array, and the flat plate array. Specifically there is shown the gas generation versus the plate configuration.

Although the invention in its preferred embodiment is best exemplified in an internal combustion engine, it can be envisioned that the concepts of the system and apparatus may be utilized in other types of controlled burners.

5

THE EMBODIMENTS OF THE INVENTION IN WHICH AN EXCLUSIVE PROPERTY OR PRIVILEGE IS CLAIMED ARE DEFINED AS FOLLOWS:

1. A burner system comprising:
 - a hydrogen/oxygen generator,
 - a housing having a water reservoir for retaining water therein having no electrolyte added thereto,
 - a pair of similar electrical voltage conductive non-oxidizing, non-corrosive, non-reactive plates positioned in said water reservoir in spaced apart relation with respect to one another,
 - a direct current voltage source having positive and a negative output terminal connected to respective ones of said pair of plates to apply a low current electrical voltage for disassociating the hydrogen gas atoms and oxygen gas atoms from the water molecules; and
 - a gas mixing chamber,
 - conduit means including a first control valve connecting the hydrogen/oxygen combustible gasses from said hydrogen/oxygen generator to said mixing chamber,
 - a source of non-combustible gas,
 - conduit means including a second control valve connecting the non-combustible gas from said non-combustible source to said mixing chamber,

18

claim 1, cont'd

said combustible gas and non-combustible
respective first and second gas control valves regulating
the gas mixture ratio of combustible/non-combustible gasses
from said mixing means,

air-intake means connected to the output
of said mixing chamber for combining air with said mixed
gasses,

a gas burner having said controlled amount
of mixed gasses from said mixing chamber and air mixed
therewith fed thereto,

means to ignite said gas/air mixture in
said gas burner, and

demand control means for varying the release
of said hydrogen/oxygen gas atoms to thereby accelerate
and deaccelerate the rate of ignition of said gas/air mixture.

1231872

2. The burner system of claim 1 wherein said air-intake means further comprises a valve for controlling the amount of air-intake to said mixed gasses in said mixing chamber.

3. The burner system of claim 1 wherein said gas burner and said means to ignite said gas/air mixture is a combustion chamber having an ignitor.

4. The burner system of claim 3 further including a drive mechanism disposed relative to said combustion chamber and wherein said drive mechanism is responsive to said gas burning.

5. The burner system of claim 3 wherein said combustion chamber further comprises outlet means for expelling the exhaust gasses therefrom, and means for returning a portion of said exhaust gasses to said mixing means.

6. The burner system of claim 3, further including a pilot light means and wherein a portion of said gas/air mixture is directed thereto,
said pilot light means being operatively associated with said combustion chamber and operative to ignite said gas/air mixture portion in said combustion chamber.

7. The burner system of claim 4 wherein said means to ignite said gasses comprises an electrical ignition means and a source of electrical energy connected to said ignitor in a closed loop arrangement with said drive mechanism.

20

1. 8. The burner system of claim 3 wherein said combustion chamber
2. comprises a mixed gas/air dispersing chamber having a series of
3. ports therein.

1. 9. The burner system claim 5 wherein said means for returning a
2. portion of said exhaust gasses to said mixing means further in-
3. cludes cooling means for cooling said exhaust gasses.

1. 10. The burner system of claim 5 wherein said means for returning
2. a portion of said exhaust gasses to said mixing means further in-
3. cludes a spark arrestor for preventing uncontrolled combustion.

1. 11. The burner system of claim 3 wherein said hydrogen generator
2. includes a source of electrical potential, and wherein said
3. source of electrical potential is connected in a closed loop
4. arrangement with said drive mechanism.

1. 12. The burner system of claim 1 wherein said demand control
2. means for accelerating and deaccelerating the ignition of said
3. gas/air mixture, further comprises:
4. varying the magnitude of said electrical potential applied to
5. said plates.

1. 13. The burner system of claim 12 wherein said demand control
2. means of varying the electrical potential applied to said plates
3. further comprises varying the voltage and maintaing the current
4. of said potential constant.

1. 14. The burner system of claim 1 wherein said demand control
2. means for accelerating and deaccelerating the ignition of said
3. gas/air mixture, further comprises:
4. means for pulsing said direct current potential.

1. 15. The burner system of claim 14 wherein said means for pulsing
2. said direct current potential further comprises varying the
3. pulse repetition rate of said pulses to control the time period
4. of said electrical potential on said water molecules.

1. 16. The burner system of claim 1 wherein said demand control
2. means for accelerating and deaccelerating the ignition of said
3. gas/air mixture, further comprises:
4. means for varying the configuration of said plates.

1. 17. The burner system of claim 1 wherein said demand control
2. means for accelerating and deaccelerating the ignition of said
3. gas/air mixture, further comprises varying the spacing between
4. said plates.

1. 18. The burner system of claim 1 wherein said demand control
2. means for accelerating and deaccelerating the ignition of said
3. gas/air mixture, further comprises:
4. means for varying the number of plates in said hydrogen
5. generator.

1. 19. The burner system of claim 15 wherein said demand control
2. means for accelerating and deaccelerating the ignition of said
3. gas/air mixture by varying the pulse repetition rate of said
4. pulsed voltage further comprises interrelating said voltage
5. magnitude with said pulse repetition rate.

20. The burner system of claim 15 wherein said demand control means for accelerating and deaccelerating the ignition of said gas/air mixture by varying the pulse repetition rate of said pulsed voltage further comprises interrelating said voltage magnitude with said pulse repetition rate and said means for varying said number of plates.

21. The burner system of claim 15 wherein said demand control means for accelerating and deaccelerating the ignition of said gas/air mixture by varying the pulse repetition rate of said pulsed voltage further comprises interrelating said voltage magnitude with said pulse repetition rate and said means for varying said number of plates, and further with said means for varying the spacing of said plates.

23

JOHNSON & HICKS
Suite 405
251 Laurier Ave. West
Ottawa, Canada
K1P 5J6
Agents for the Applicant

22. A combustion system comprising:
- (a) means to produce a combustible gas such as hydrogen or the like;
 - (b) means for mixing said combustible gas with a non-combustible gas provided from a suitable source and thereby produce a gas mixture,
 - (c) means for mixing said gas mixture with air and direct the same into a combustion chamber of the combustion system and means controllably varying selectively the production of combustible gas as required for combustion based on demand in the combustion system.
23. A combustion system as defined in claim 22 wherein said means to produce a combustible gas comprises apparatus for subjecting water to electrical energy and wherein said means for varying the production of combustible gas comprises means for selectively varying said electrical energy.
24. A combustion system as defined in claim 23 wherein the voltage of the electrical energy is varied.
25. The combustion system as defined in claim 23 wherein said electrical energy is direct current and means are provided for pulsing the same.
26. A combustion system as defined in claim 22 wherein said non-combustible gas comprises gasses exhausted from combustion in said combustion system. ❄

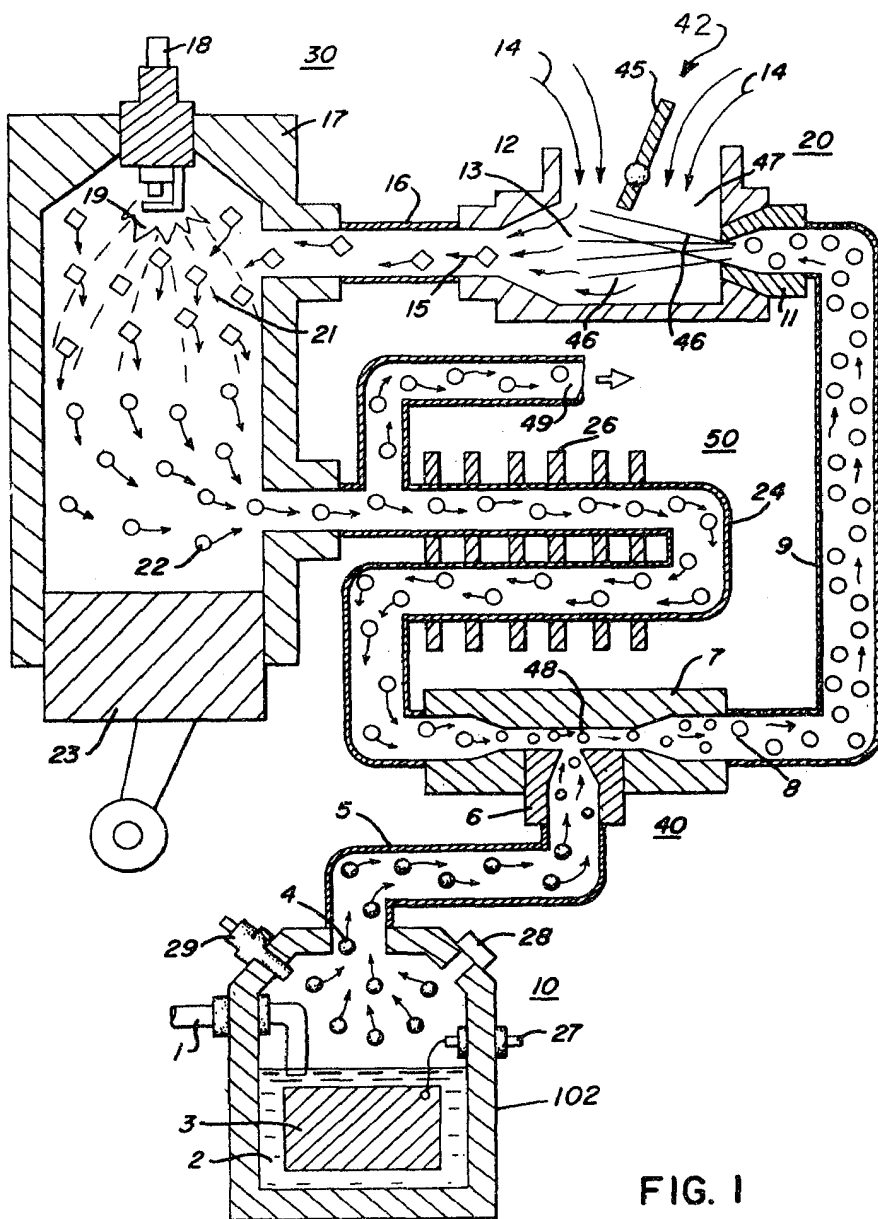

FIG. 1

Johnson & Hicks
 PATENT AGENTS

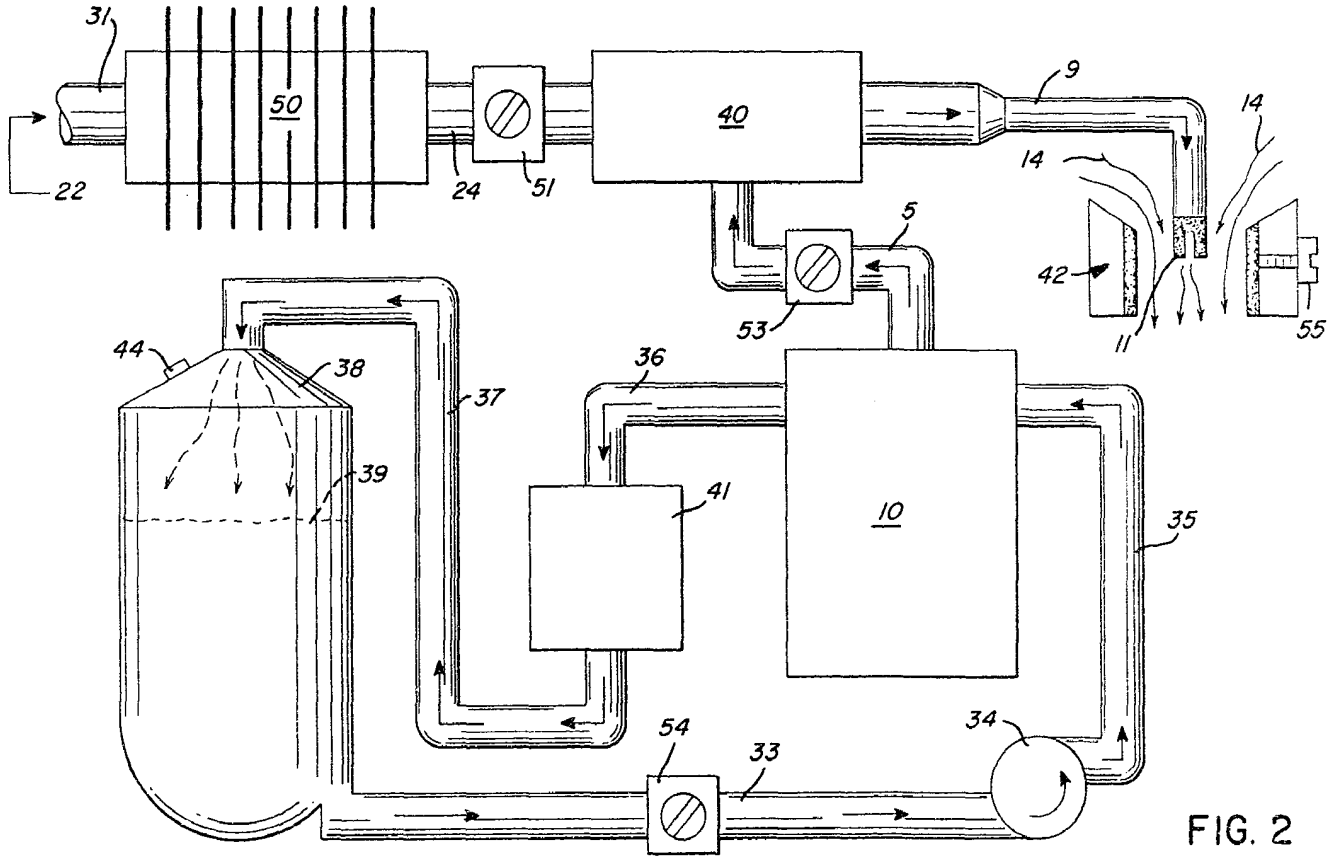

FIG. 2

Johnson & Hicks
 PATENT AGENTS

1231872
 12-2

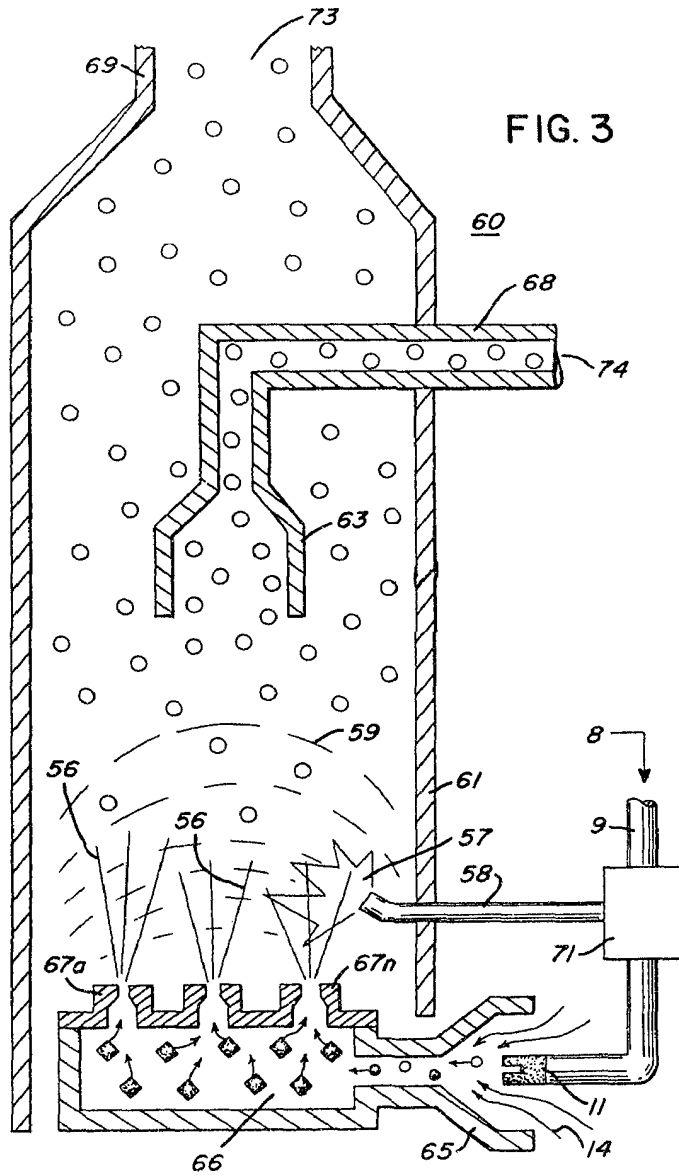

FIG. 3

Johnson & Hicks
PATENT AGENTS

Johnson & Sklar
PATENT AGENTS

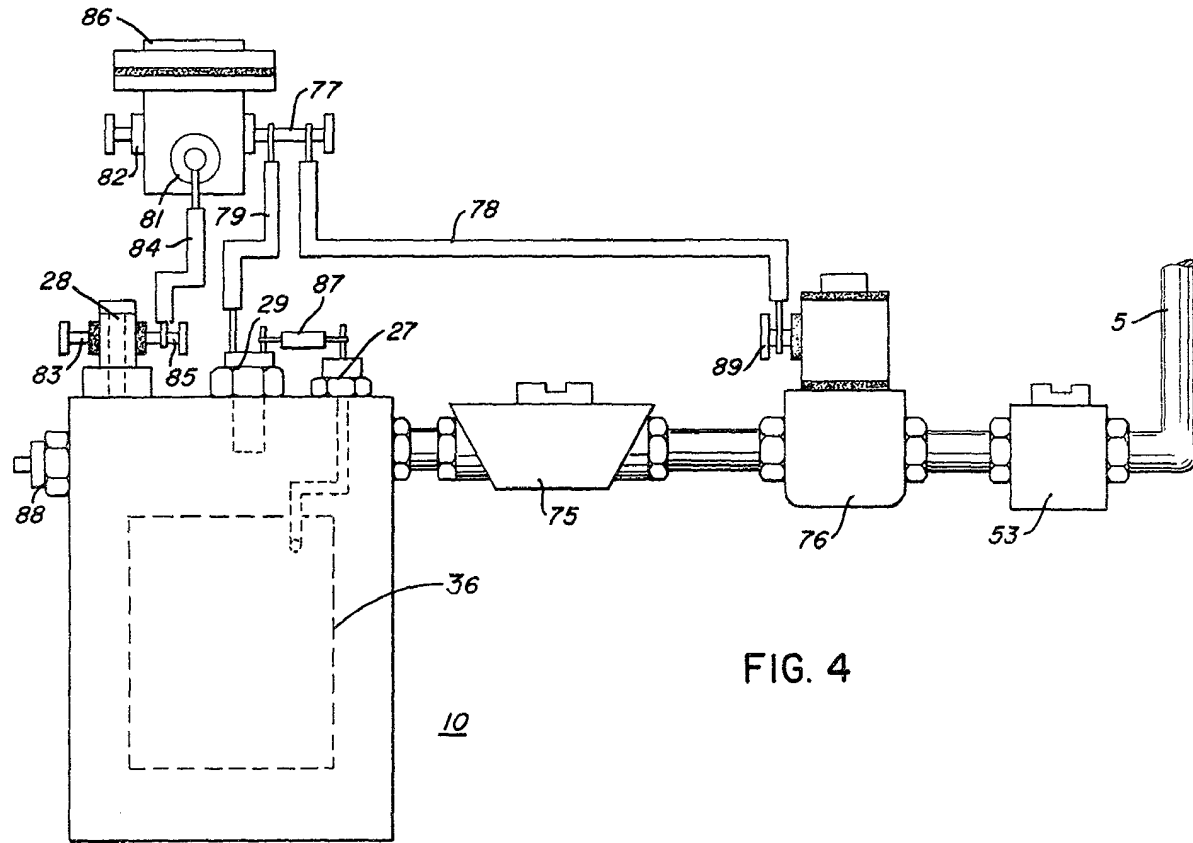
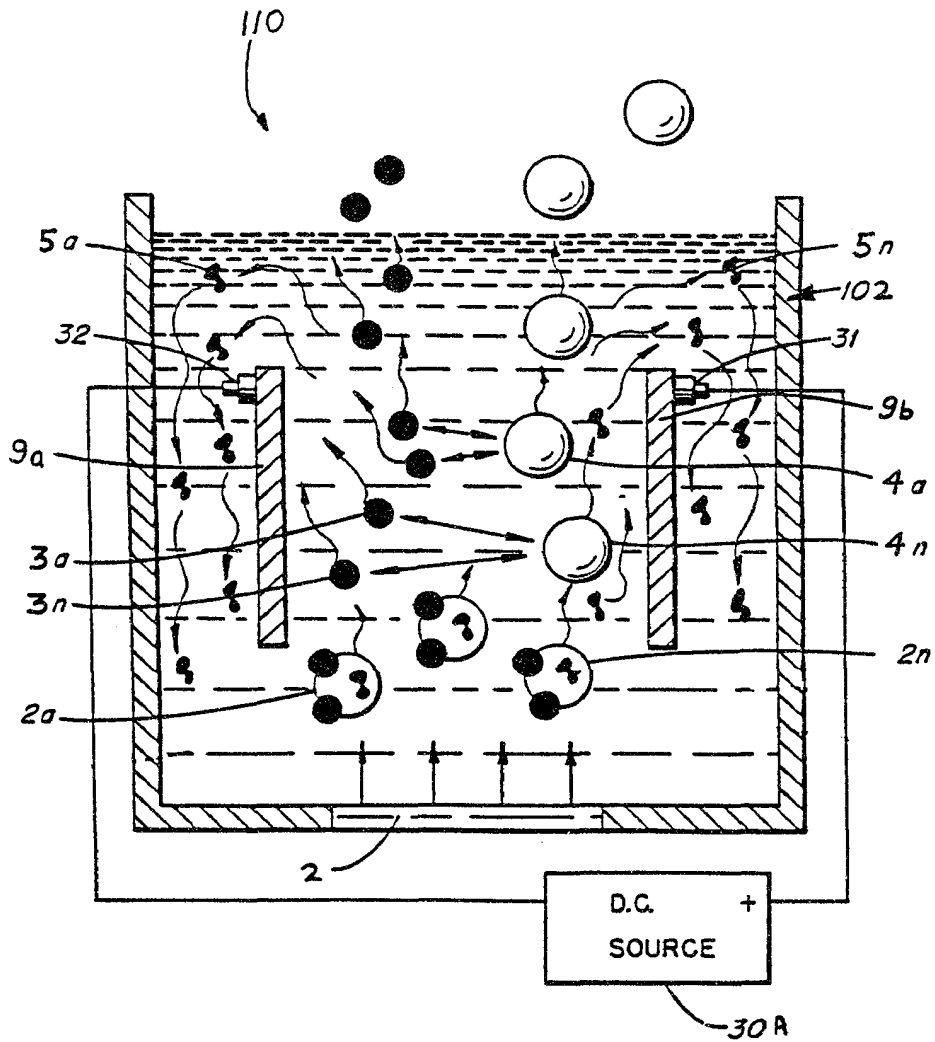

FIG. 4

1231872
12-4

FIG. 5



Johnson + Hicks

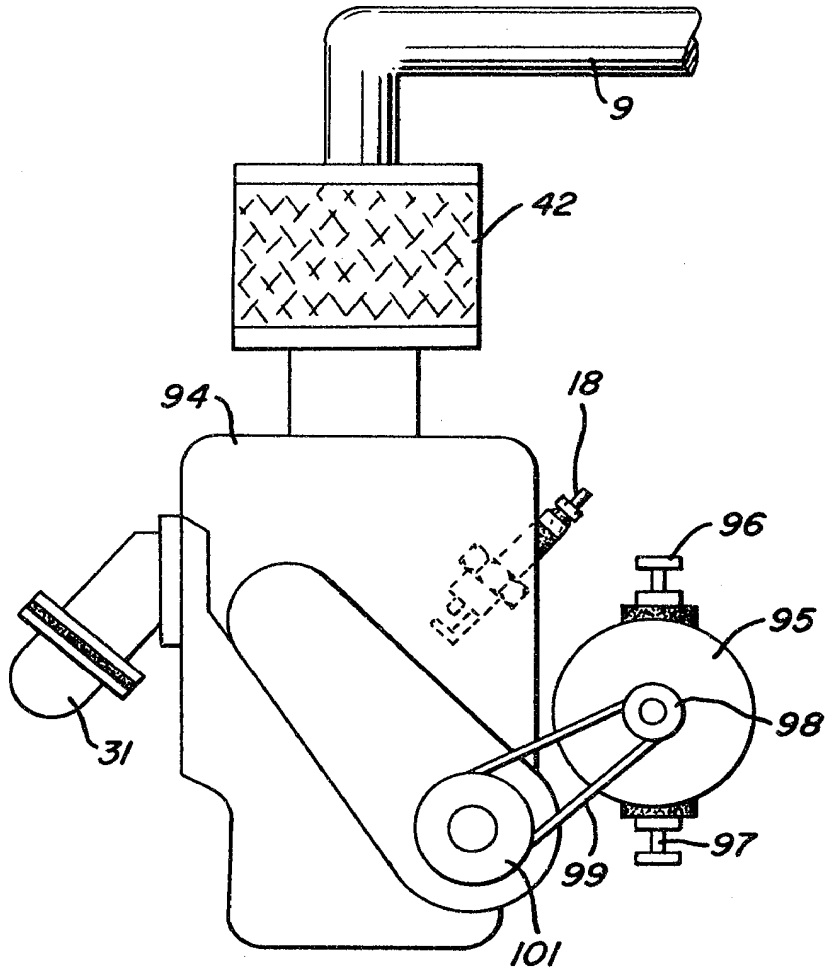
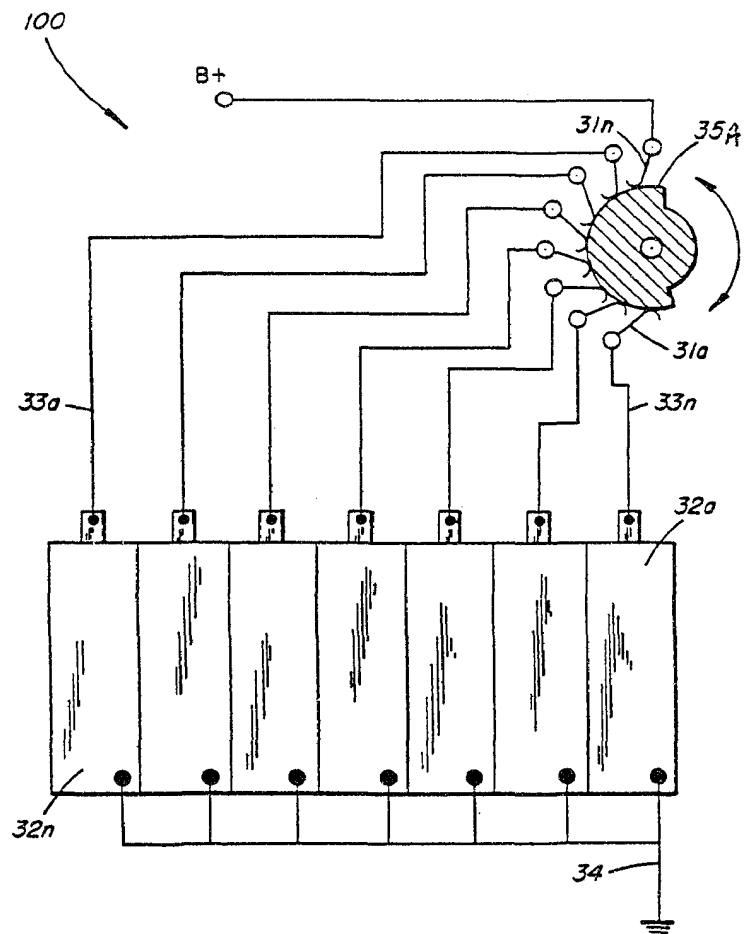

FIG. 6

Johnson & Hicks
PATENT AGENTS

FIG. 7



Johnson + Hicks

Johnson & Atkins
PATENT AGENTS

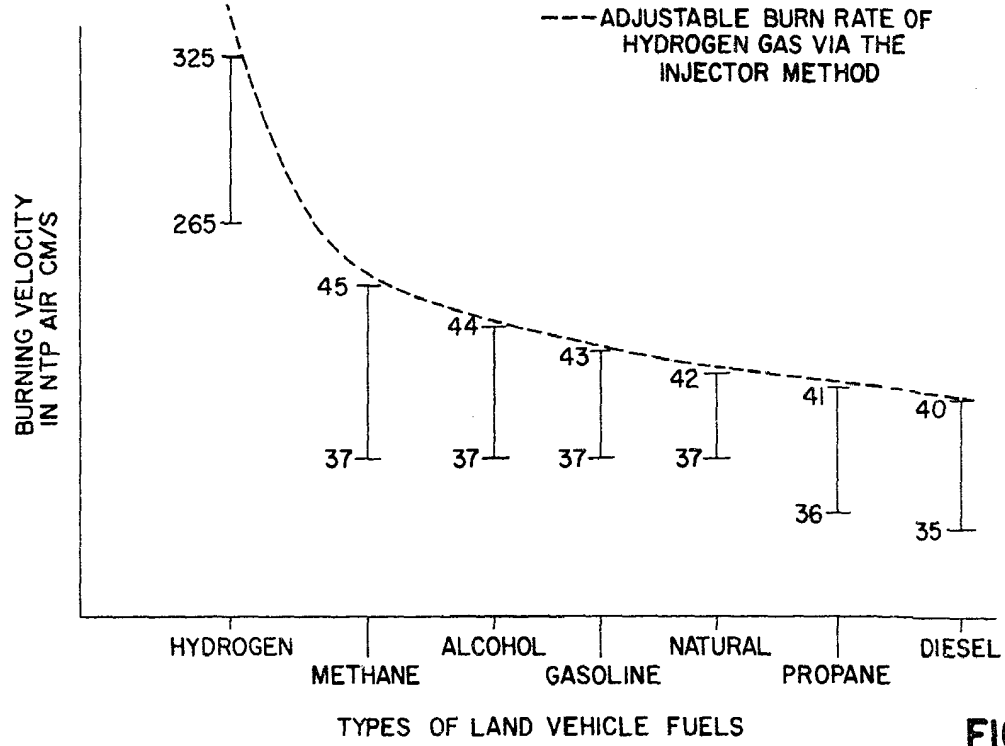
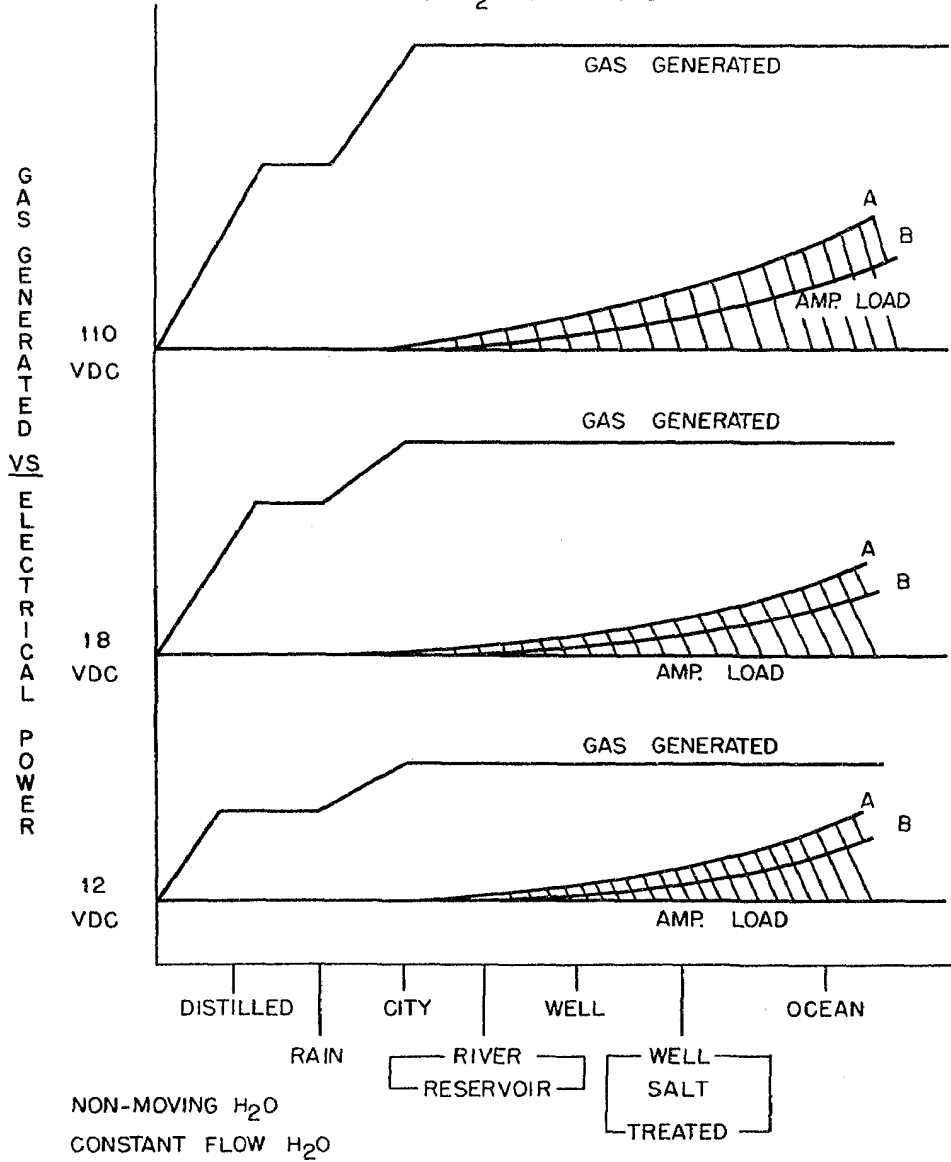

FIG. 8

1231872
12-8

FIG. 9

GAS GENERATED VS. DIFFERENT APPLIED VOLTAGES VS. H₂O CONDITIONS



Johnson & Hicks
PATENT AGENTS

FIG. 10

GAS GENERATED VS. PULSE VOLTAGE RATE

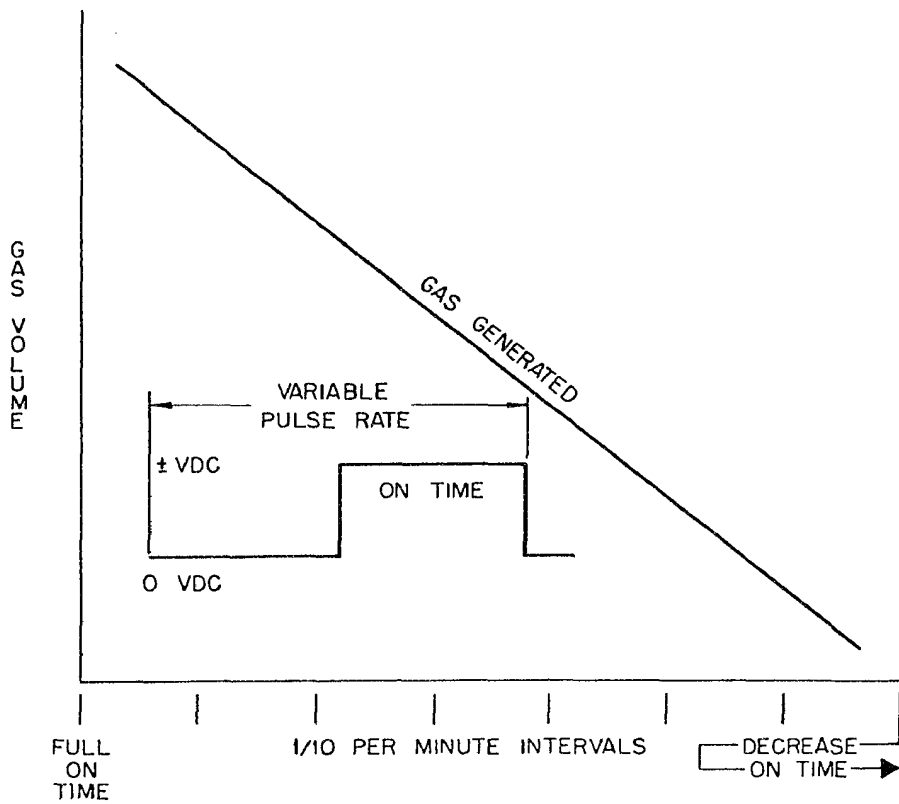

Johnson & Hicks
PATENT AGENTS

FIG. II

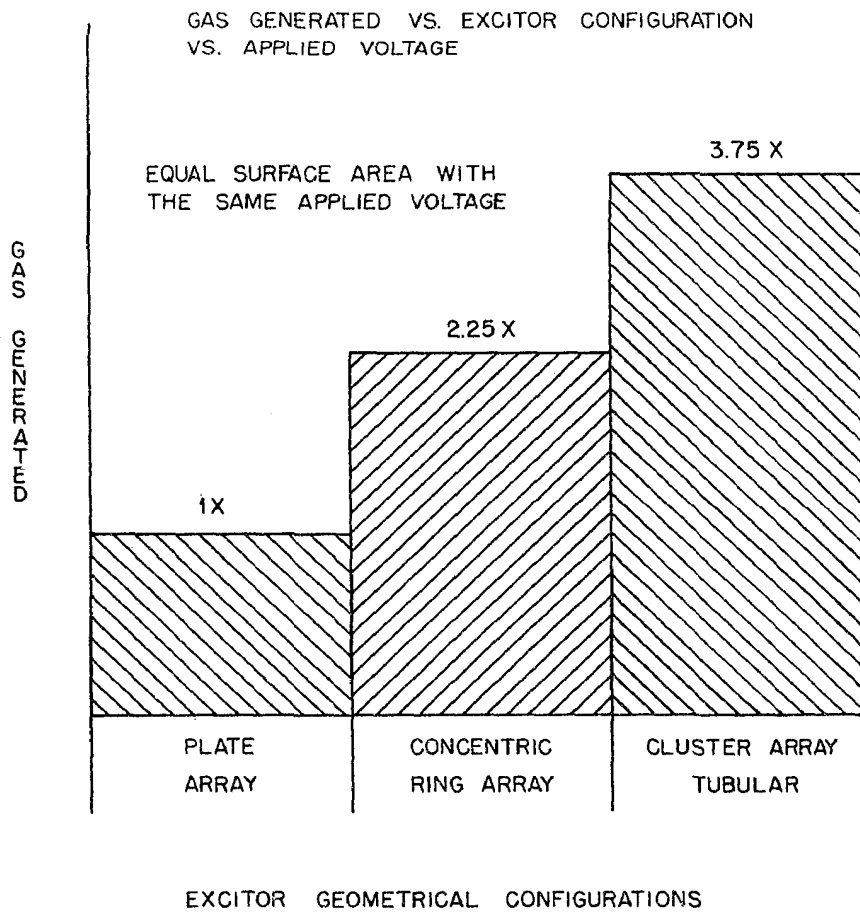

Johnson & Hicks
PATENT AGENTS

12-12

FIG. 12

GAS GENERATED VS. APPLIED VOLTAGE VS.
PLATE SEPARATION

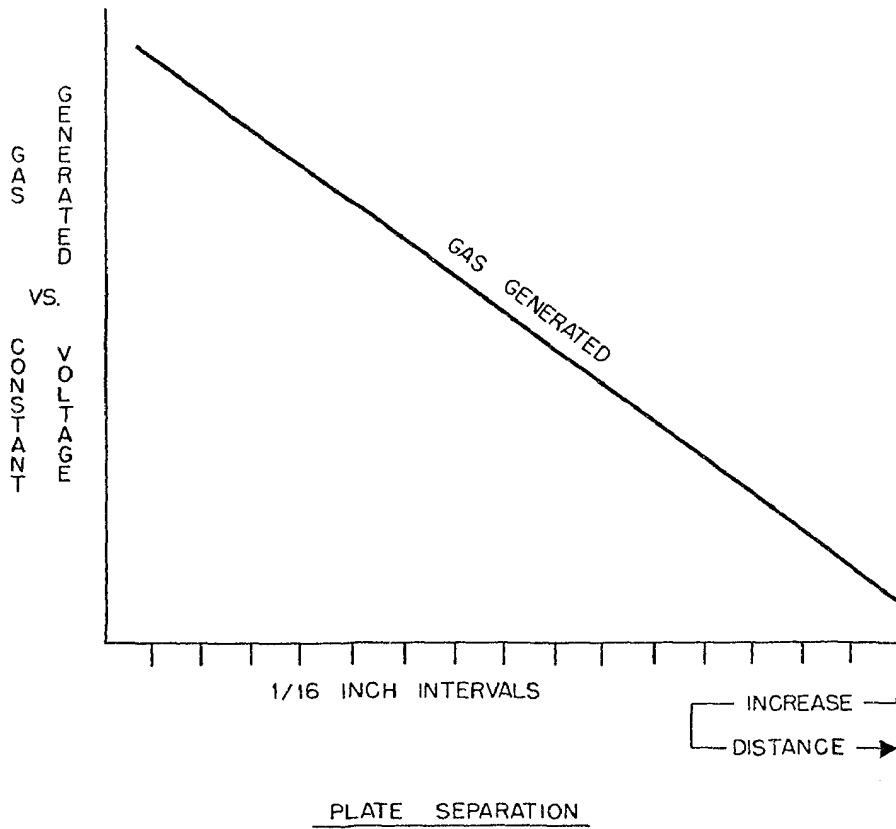

Johnson & Hicks
PATENT AGENTS